

Bluetooth class 2 module with embedded HCI FW

Features

- Bluetooth specification V.1.2 compliant
- Transmission rate up to 721 Kbps
- Output power class 2 (0 dBm typical)
- Working distance up to 10 meters
- ACL & SCO links
- AFH interference resistance
- Supports USB (1.1) /UART/PCM (Pulse Code Modulation)/SPI/ I²C interfaces
- Optimized link manager and control
- Support wireless LAN coexistence in collocated scenario
- Integrated 4Mbit Flash, 64Kbytes RAM, 4KBytes ROM
- 3.3V single supply voltage
- Hardware based UART flow control

Applications

- Serial cable replacement
- Industrial control
- Laptops
- POS terminals
- Data acquisition equipment
- Internet access points
- Machine control
- Sensor monitoring
- Robotic and bionic control
- Security control
- Patient monitoring
- Audio gateway applications
- Hands-free sets
- Wireless printers
- Cordless terminals
- Laptops, PCs and accessories
- Hand held devices and accessories
- HID devices (keyboard, mouse, joystick, game controller...)

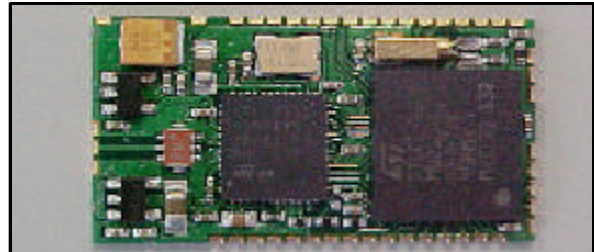

Description

ST Bluetooth Modules are highly integrated for easy implementation in embedded applications. Class 2 modules enable wireless communication with other Bluetooth enabled devices up to 10 m away. The GS-BT2416C2.H integrates on a unique FR4 PCB support: BT 1.2 radio and baseband, memory, 32 KHz and 13 MHz oscillator as well Vreg. The Module embeds Customer Framework up to HCI level allowing interoperability with HCI Top resident on Host. The antenna has not been included in order to grant a degree of freedom to the user in selecting the most suitable design and placement between external and integrated antenna that could be SMA aerial or a low cost antenna trace designed on PCB. For more details please refer to GS-BT2416C2DB Application Note. The GS-BT2416C2.H is the HCI module of the GS-BT2416C2.xx series. GS-BT2416C2.H is BQB qualified. Conformance testing through Bluetooth qualification program enables a fast time to market after system integration by ensuring a high degree of compliance and interoperability.

Contents

- 1 Certifications 3**
- 2 Maximum ratings 4**
 - 2.1 Absolute maximum ratings 4
 - 2.2 Operating ranges 4
- 3 Electrical characteristics 5**
 - 3.1 DC I/O specification 5
- 4 Bluetooth section 5**
 - 4.1 RF performance characteristics 6
- 5 Integrate firmware 7**
 - 5.1 Features 7
 - 5.2 Command interface 7
 - 5.3 Usage scenarios 7
- 6 Application information 8**
 - 6.1 Antenna reference 9
- 7 Block diagram 10**
- 8 Pin settings 11**
 - 8.1 Pin connections 11
 - 8.2 Pin descriptions 11
- 9 Mechanical dimensions 14**
- 10 Ordering information scheme 16**
- 11 Revision history 17**

1 Certifications

- CE Compliant (IMQ Exp.Opinion 0081-AREF00017
 - Safety EN60950-1 (2001)
 - EMC EN301 489 17V1.2.1
 - Radio ES 300 328 V1.6.
- FCC certified on GS-BT2416C2DB (for a more exhaustive explanation, please refer to GS-BT2416C2DB Application Note)
- FCC ID: S9N16C2
- BQB qualified device BQB ID: B012535

2 Maximum ratings

2.1 Absolute maximum ratings

Absolute maximum ratings (see table 2) indicate limits beyond which damage to the device may occur. Sustained exposure to these limits will adversely affect device reliability.

Operating ranges (see table 3) define the limits for functional operation and parametric characteristics of the module. Functionality outside these limits is not implied

Table 1. Absolute maximum ratings

Symbol	Parameter	Values		Unit
		Min	Max	
V_{DD}	Module supply voltage		4	V
V_{IN}	Input voltage on any digital pin	$V_{SS1}-0.5$	$V_{DD}+0.3$	V
T_{stg}	Storage temperature	-40	+85	°C
T_{sold}	Soldering temperature		240	

2.2 Operating ranges

Table 2. Operating ranges

Symbol	Parameter	Conditions	Values			Unit
			Min	Typ	Max	
V_{DD}	Module supply voltage	$-20^{\circ}\text{C} < T < 70^{\circ}\text{C}$	3.13	3.3	3.47	V
T_{stg}	Operating ambient temperature		-20		+70	°C

3 Electrical characteristics

3.1 DC I/O specification

Table 3. DC Input / Output specification

Symbol	Parameter	Conditions	Values			Unit
			Min	Typ	Max	
V _{il}	Low level input voltage	3.13 V < V _{DD} < 3.47 V			0.8	V
V _{ih}	High level input voltage	3.13 V < V _{DD} < 3.47 V	2			V
V _{hyst}	Schmitt trigger hysteresis	3.13 V < V _{DD} < 3.47 V	0.4			V
V _{ol}	Low level output voltage	Io load = pin drive capability			0.15	V
V _{oh}	High level output voltage	Io load = pin drive capability	V _{DD} -0.15			V

4 Bluetooth section

Table 4. Bluetooth section

Symbol	Parameter	Conditions	Values			Unit
			Min	Typ	Max	
CHs	Channel space			1		MHz
Hop	Hopping			1600		Hops/sec
13M CK	System clock			13		MHZ
	System clock stability	- 20°C to 70°C	- 20		20	ppm
LP CK	Low power clock			32		kHz
	Low power clock accuracy		- 200		200	ppm
Tra	Transmission rate asynchronous				721	kbits/sec
Trs	Transmission rate synchronous				432	kbits/sec
Iop	Operation current TX mode			90		mA
	Operation RX mode			50		mA

4.1 RF performance characteristics

In the performance characteristics table the following applies:

- Test condition: nominal
 - Voltage typical Vdd 3.3V
 - Temperature typical Tamb 25°C

Parameters are given at antenna pin

Table 5. Transmitter and receiver performance characteristics

Symbol	Parameter	Conditions	Min	Typ	Max	Unit
TX Pout	TX Output power	2.402 GHz		0		dBm
		2.441 GHz		0		dBm
		2.480 GHz		0		dBm
ACP	TX output spectrum adjacent channel power	IM-NI = 2		- 36		dBm
		IM-NI ≥ 3		- 50		dBm
RX sens	Receiver sensitivity	@BER 0.1%		- 74		dBm

Table 6. Synthesizer performance characteristics

Symbol	Parameter	Conditions	Min	Typ	Max	Unit
RF in RF out	Input & Output frequency range		2402		2480	MHz
TX out	TX output spectrum at -20 dB Bandwidth			920	1000	kHz
ΔF	TX initial carrier frequency tolerance		- 75		75	kHz
$ \Delta F - \text{pn} $	TX carrier frequency drift	DH1 data packet			25	kHz
		DH3 data packet			40	kHz
		DH5 data packet			40	kHz
$ \Delta F/50\mu\text{s} $		Drift rate			20	Hz

5 Integrate firmware

The GS-BT2416C2.H includes Customer Framework up to HCI (Host Control Interface)

Figure 1. HCI firmware implementation

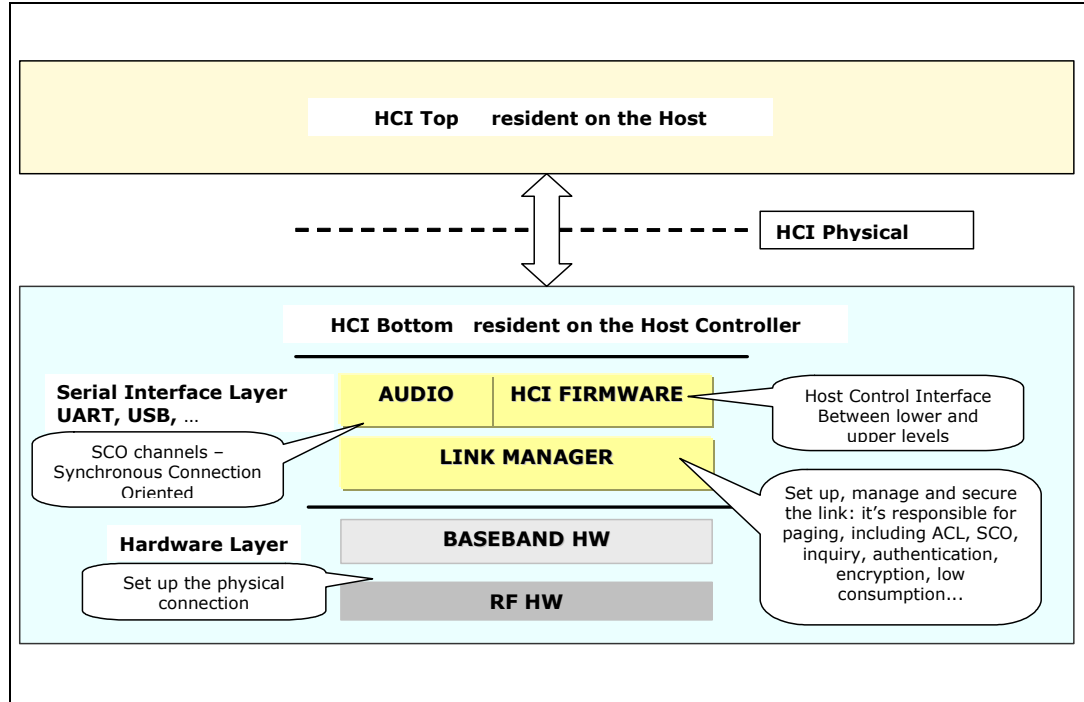

5.1 Features

The module with HCI embedded is interoperable with qualified BT stack protocols and suitable for any BT applications.

5.2 Command interface

The HCI commands are accessible through the Serial Port using the Host Control SW or any HCI SW for example Bluesoleil (most popular Bluetooth PC open SW).

5.3 Usage scenarios

The module with embedded HCI FW is completely open to any Custom implementation, strictly depending on the BT stack and profiles that will be added. Module can be configured both as master or slave. Master can support point to point connection or standard point to multi point Pico net up to seven points.

6 Application information

Here below there are some suggestions to better implement the module in the final application.

- Module is usually put on a motherboard, avoid that traces with switching signals are routed below the module. The best would be to have a ground plane underneath the module.
- Connect the supply voltage ground of the module with the other grounds present on the motherboard in a star way.
- Keep the RF ground separate from the module supply voltage ground; the two grounds are already connected inside the module in one point, see below a possible implementation.

Figure 2. Module foot print

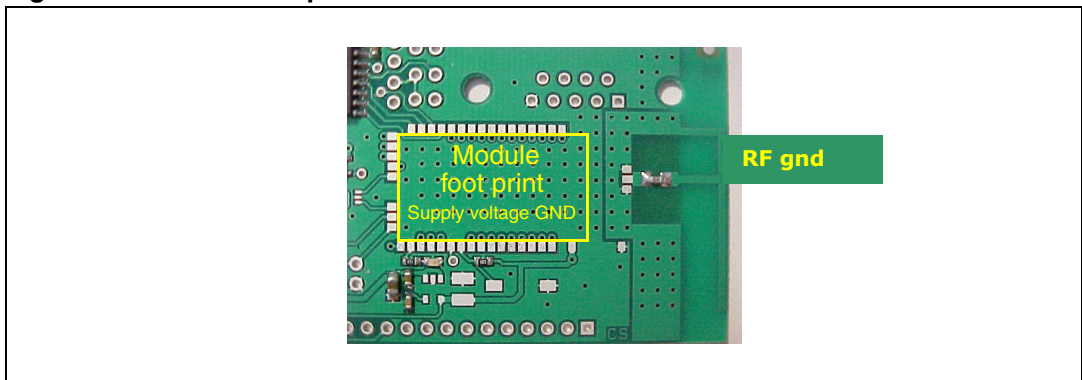

6.1 Antenna reference

RF output pin must be connected to an antenna which could be:

- Antenna directly printed on the pcb (Figure 4)
- Integrated antenna as, for example, Antenova 30-30-A5839-01 , Murata ANCV12G44SAA127, Pulse W3008 , Yageo CAN4311153002451K. (Figure 5)
- External antenna connected by means a SMA connector (Figure 6)

Figure 3. Antenna on PCB Figure 4. Antenna examples Figure 5. SMA connector for external antenna



- Despite of the type of antenna chosen, the connection between the RF out pin and the antenna must be executed in such a way that the connection trace must be matched to have characteristic impedance (Z_0) of 50 ohm to get the maximum power transfer.
- Matching for 50ohm is depending on the various factors , elements to be taken into consideration are:
 - Type of material, i.e. FR4
 - The electrical characteristics of the material ,i.e. the ϵ_r , electric constant at 2.4GHz
 - Mechanical dimensions of the PCB and traces ,i.e. pcb thickness , trace/ reference ground thickness, trace width , trace thickness
 - Just to give an example , using a 1mm thick FR4 board , with an $\epsilon_r = 4.3$ at 2.4GHz , with Cu thickness of 41 μm , the resulted width of 50ohm strip-line is 1.9 mm (Microstrip type calculation).

Figure 6. Parameters for trace matching

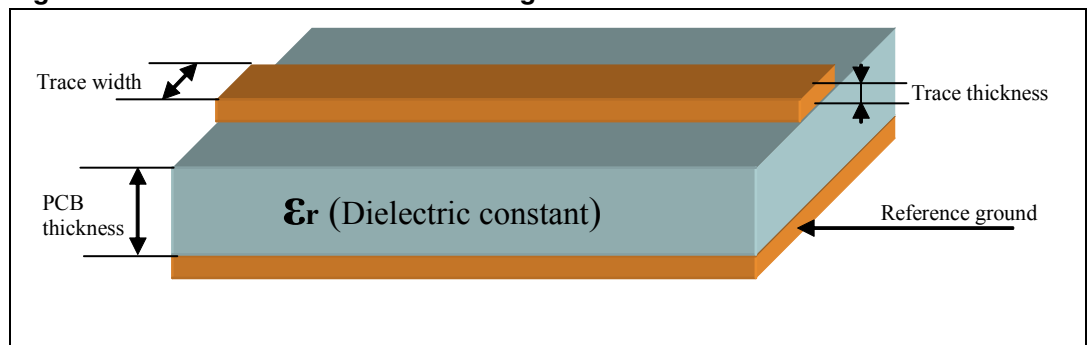

Tools for calculating the characteristic impedance, based on the physical and mechanical characteristics of the pcb , can be easily found on the web.

7 Block diagram

Figure 7. Block diagram

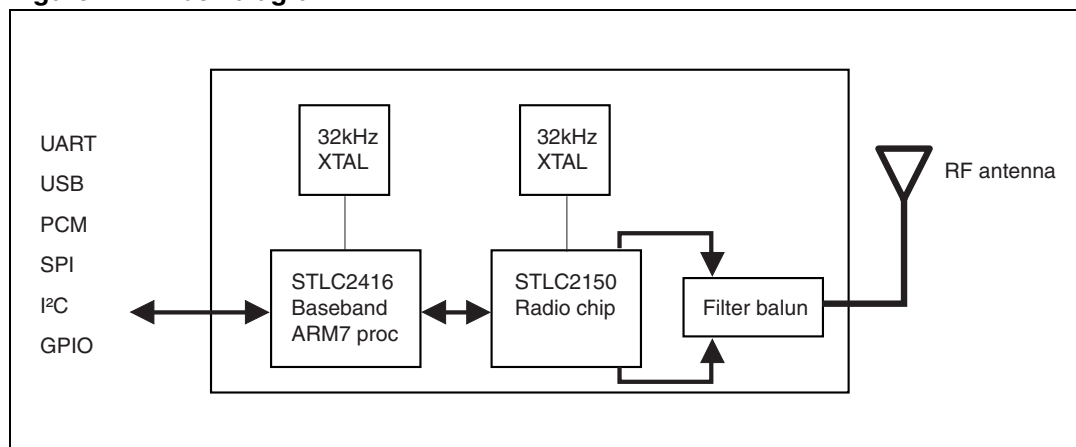

8 Pin settings

8.1 Pin connections

Figure 8. Pin connection diagram

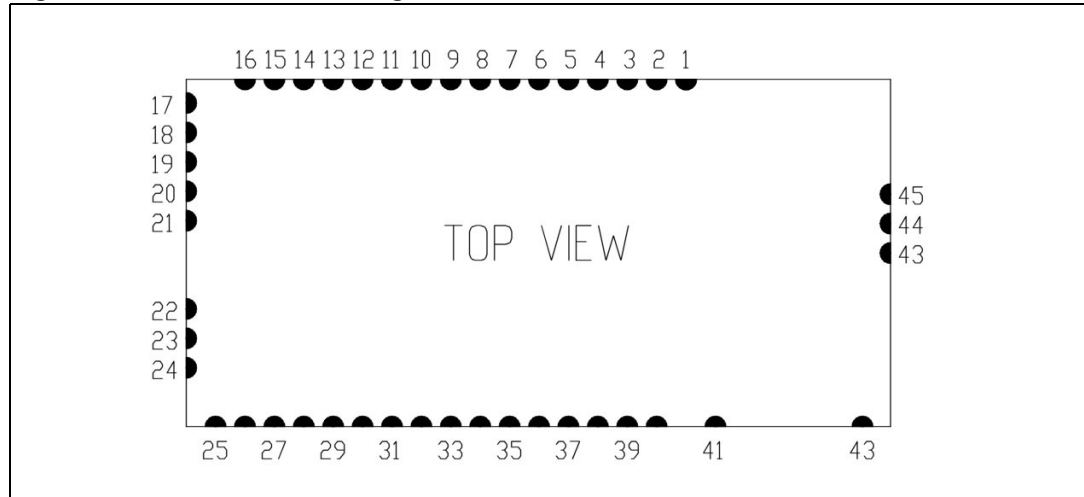

8.2 Pin descriptions

Table 7. Pin descriptions

Pin N°	Name	I/O	Description
Power, Ground and system signal			
42	Vss ₁	---	GND
41	Vdd	---	Module supply voltage- Single 3.3V
23	RESET	I	Reset pin (active low)
24	BOOT	I	External downloading Enable (active low) internally pull-upped to 1.8V by 10kohm
35	LP CLOCK OUT	O	32kHz Out
6	INT1	I	External Interrupt signal internally connected to VSS1 with 10K. / If not used connect to VSS1
General purpose signals			
25	GPIO0	I/O	General purpose I/O line
26	GPIO1	I/O	General purpose I/O line
27	GPIO2	I/O	General purpose I/O line
28	GPIO3	I/O	General purpose I/O line
29	GPIO4	I/O	General purpose I/O line
30	GPIO5	I/O	General purpose I/O line

Table 7. Pin descriptions (continued)

Pin N°	Name	I/O	Description
31	GPIO6	I/O	General purpose I/O line
32	GPIO7	I/O	General purpose I/O line
33	GPIO8	I/O	General purpose I/O line
34	GPIO9	I/O	General purpose I/O line
36	GPIO11	I/O	General purpose I/O line
37	GPIO12	I/O	General purpose I/O line
38	GPIO13	I/O	General purpose I/O line
39	GPIO14	I/O	General purpose I/O line
40	GPIO15	I/O	General purpose I/O line
Test interface signals			
1	TDI	---	JTAG pin
4	TDO	---	JTAG pin
2	TMS	---	JTAG pin
3	NTRST	---	JTAG pin
5	TCK	---	JTAG pin If not used connect to VSS1
I2C interface signals			
7	I2C_dat	I/O	I2C bus interface data To be connected to VDD with 10 K. resistor
8	I2C_clk	I/O	I2C bus interface clock To be connected to VDD with 10 K. resistor
PCM interface signals			
10	PCM_SYNC	I/O	PCM 8kHz synch
9	PCM_CLK	I/O	PCM clock
12	PCM_A	I/O	PCM Data In/Out
11	PCM_B	I/O	PCM Data In//Out
USB interface signals			
21	USB_DN	I/O	USB data - If not used connect to VSS1
22	USB_DP	I/O	USB data + If not used connect to VSS1
UART interface signals			
13	UART2_RXD	I	UART2 data input If not used connect to VDD
14	UART2_TXD	O	UART2 data output
15	UART2_I1	I	UART2 clear to send input If not used connect to VDD

Table 7. Pin descriptions (continued)

16	UART2_02	O	UART2 ready to send output
Pin N°	Name	I/O	Description
SPI interface signals			
17	SPI_FRM	I/O	Synchronous Serial Interface frame synch
18	SPI_CLK	I/O	Synchronous Serial Interface clock
19	SPI_TXD	O/T	Synchronous Serial Interface transmit data
20	SPI_RXD	I	Synchronous Serial Interface receive data If not used connect to VSS1
Antenna signals			
43	Vss ₂ (RF GND)	---	RF GND
44	+ANTENNA	---	Antenna out
45	Vss ₂ (RF GND)	---	RF GND

9 Mechanical dimensions

In order to meet environmental requirements, ST offers these devices in ECOPACK® packages. These packages have a Lead-free second level interconnect . The category of second level interconnect is marked on the package and on the inner box label, in compliance with JEDEC Standard JESD97. The maximum ratings related to soldering conditions are also marked on the inner box label. ECOPACK is an ST trademark. ECOPACK specifications are available at: www.st.com.

Figure 9. Mechanical dimensions

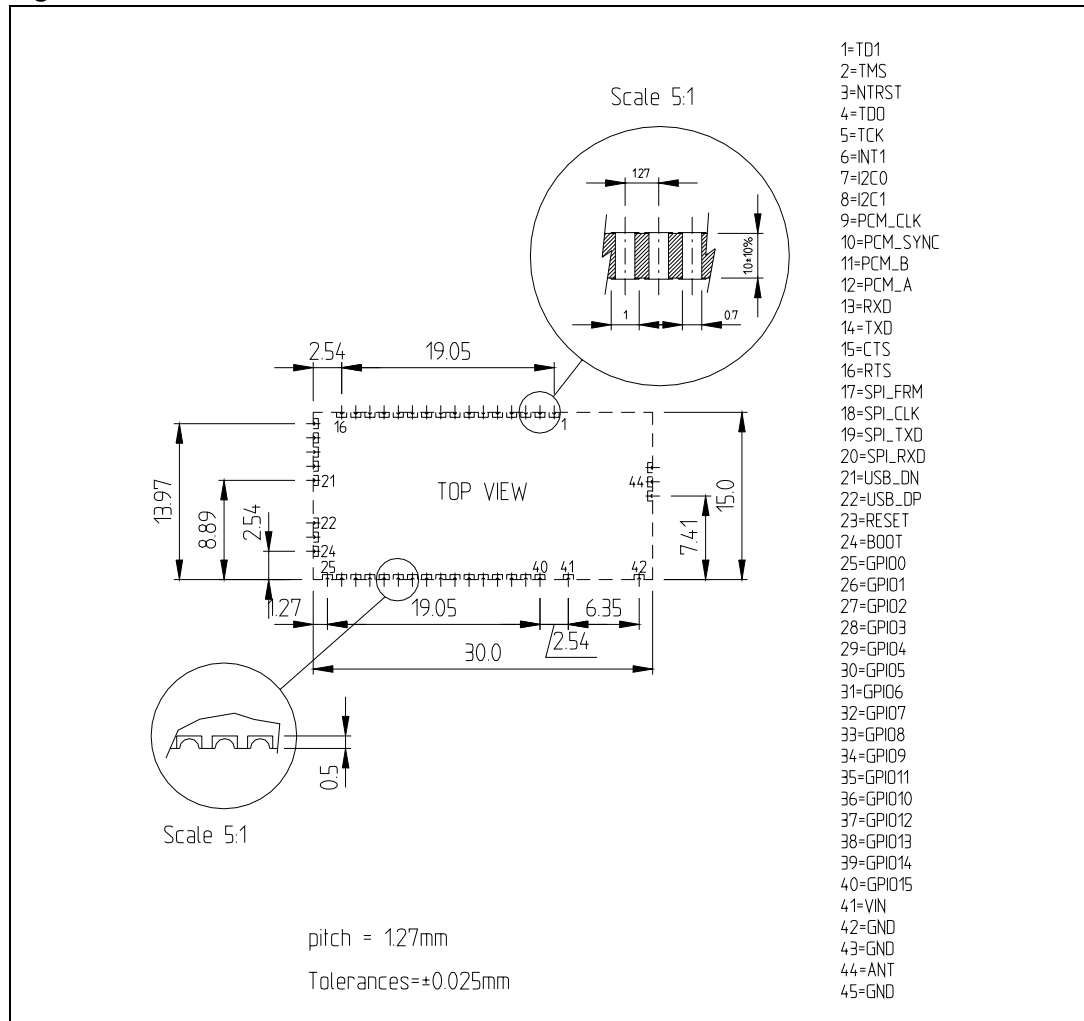
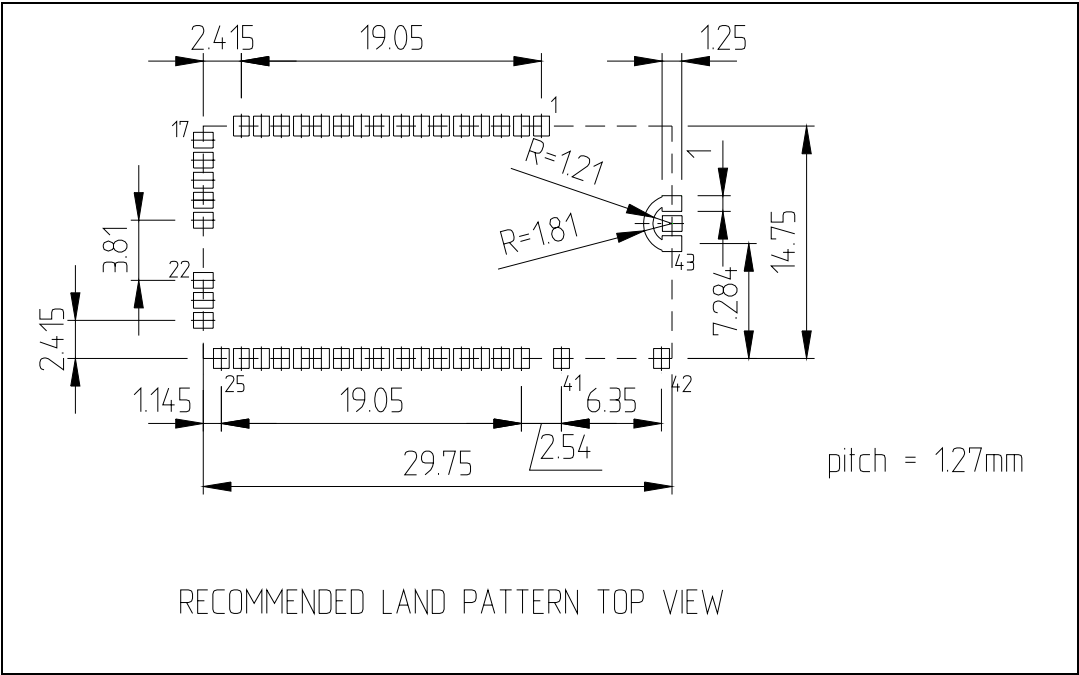

Figure 10. Land pattern and connection diagram



10 Ordering information scheme

Table 8. Ordering information scheme

	GS-BT	2416	C2	H
Bluetooth modules				
V 1.2 compliant				
Class 2				
HCI firmware				

11 Revision history

Table 9. Document revision history

Date	Revision	Changes
04-Sep-2007	1	First release

Please Read Carefully:

Information in this document is provided solely in connection with ST products. STMicroelectronics NV and its subsidiaries ("ST") reserve the right to make changes, corrections, modifications or improvements, to this document, and the products and services described herein at any time, without notice.

All ST products are sold pursuant to ST's terms and conditions of sale.

Purchasers are solely responsible for the choice, selection and use of the ST products and services described herein, and ST assumes no liability whatsoever relating to the choice, selection or use of the ST products and services described herein.

No license, express or implied, by estoppel or otherwise, to any intellectual property rights is granted under this document. If any part of this document refers to any third party products or services it shall not be deemed a license grant by ST for the use of such third party products or services, or any intellectual property contained therein or considered as a warranty covering the use in any manner whatsoever of such third party products or services or any intellectual property contained therein.

UNLESS OTHERWISE SET FORTH IN ST'S TERMS AND CONDITIONS OF SALE ST DISCLAIMS ANY EXPRESS OR IMPLIED WARRANTY WITH RESPECT TO THE USE AND/OR SALE OF ST PRODUCTS INCLUDING WITHOUT LIMITATION IMPLIED WARRANTIES OF MERCHANTABILITY, FITNESS FOR A PARTICULAR PURPOSE (AND THEIR EQUIVALENTS UNDER THE LAWS OF ANY JURISDICTION), OR INFRINGEMENT OF ANY PATENT, COPYRIGHT OR OTHER INTELLECTUAL PROPERTY RIGHT.

UNLESS EXPRESSLY APPROVED IN WRITING BY AN AUTHORIZED ST REPRESENTATIVE, ST PRODUCTS ARE NOT RECOMMENDED, AUTHORIZED OR WARRANTED FOR USE IN MILITARY, AIR CRAFT, SPACE, LIFE SAVING, OR LIFE SUSTAINING APPLICATIONS, NOR IN PRODUCTS OR SYSTEMS WHERE FAILURE OR MALFUNCTION MAY RESULT IN PERSONAL INJURY, DEATH, OR SEVERE PROPERTY OR ENVIRONMENTAL DAMAGE. ST PRODUCTS WHICH ARE NOT SPECIFIED AS "AUTOMOTIVE GRADE" MAY ONLY BE USED IN AUTOMOTIVE APPLICATIONS AT USER'S OWN RISK.

Resale of ST products with provisions different from the statements and/or technical features set forth in this document shall immediately void any warranty granted by ST for the ST product or service described herein and shall not create or extend in any manner whatsoever, any liability of ST.

ST and the ST logo are trademarks or registered trademarks of ST in various countries.

Information in this document supersedes and replaces all information previously supplied.

The ST logo is a registered trademark of STMicroelectronics. All other names are the property of their respective owners.

© 2007 STMicroelectronics - All rights reserved

STMicroelectronics group of companies

Australia - Belgium - Brazil - Canada - China - Czech Republic - Finland - France - Germany - Hong Kong - India - Israel - Italy - Japan - Malaysia - Malta - Morocco - Singapore - Spain - Sweden - Switzerland - United Kingdom - United States of America

www.st.com